

SCAPIN

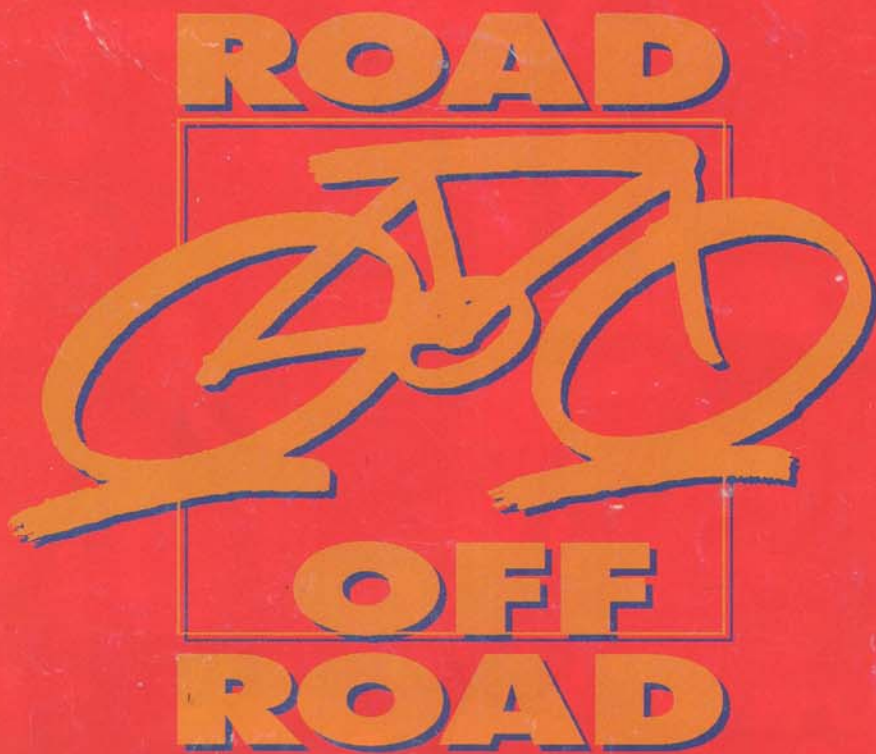

1998

Con una esperienza di 40 anni, SCAPIN ha fuso la tradizione dei vecchi maestri telaisti con le tecnologie più avanzate in termini di progettazione e di produzione. Le biciclette ed i telai SCAPIN nascono dal sofisticato sistema computerizzato Ciclocad e sono realizzati con materiali d'avanguardia, in molti casi prodotti in esclusiva per SCAPIN. Per la saldatura, SCAPIN ha adottato un sofisticato ed avanzato sistema robotizzato che garantisce una altissima ed uniforme qualità. Per la verniciatura, infine, SCAPIN utilizza tecniche avanzate di salvaguardia ambientale.



With nearly 40 years of experience, SCAPIN has united the tradition of old master frame-makers with cutting-edge technologies in terms of production and design. SCAPIN bicycles and frames are designed using the sophisticated Ciclocad system and manufactured with new age materials, in many cases produced exclusively for SCAPIN. For the welding, SCAPIN has adopted a sophisticated and advanced robotized system which guarantees constant top quality. And lastly, with the paintwork, SCAPIN utilizes advanced methods that safeguard the environment.

Mit seiner fast 40-jährigen Erfahrung hat SCAPIN die Tradition der alten Rahmenherstellungsmeister mit den höchstentwickelten Technologien im Hinblick auf Planung und Produktion verschmolzen. Die Fahrräder und Rahmen der Firma SCAPIN entstehen mit Hilfe des ausgefeilten Computersystems Ciclocad und werden aus fortschrittlichsten Materialien hergestellt, die in vielen Fällen exklusiv für SCAPIN produziert werden. Zur Verschweißung wendet SCAPIN ein hochentwickeltes und modernes Robotersystem an, das ein gleichmäßiges und ausgesprochen hohes Qualitätsniveau gewährleistet. Zur Lackierung schließlich verwendet SCAPIN fortschrittliche, den Umweltschutz berücksichtigende Techniken.



series

TR-K

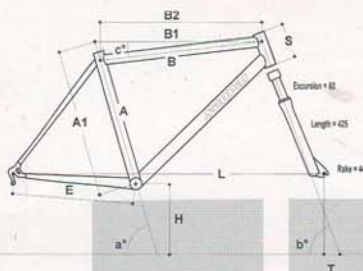

A inch	A mm	A1	B	B1	B2	a°	b°	c°	E	H	L	T	S
15.6	395	508	541	562	530	73.50	70.00	11.60	423	302	1032	75.9	93
16.7	425	508	560	579	555	73.00	70.00	8.10	423	302	1063	75.9	93
17.9	455	508	572	585	570	73.00	70.00	5.00	423	302	1069	75.9	93
19.1	485	516	581	589	580	73.00	70.00	2.90	423	302	1074	75.9	103
20.1	510	527	590	595	590	73.00	70.00	1.60	423	302	1080	75.9	115
21.1	535	547	595	599	595	73.00	70.00	1.10	423	302	1085	75.9	136



series

UR-K

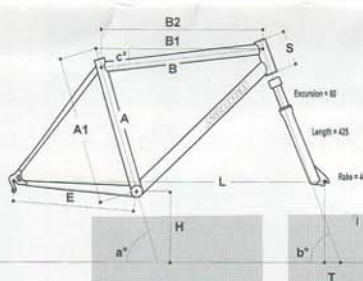

A inch	A mm	A1	B	B1	B2	a°	b°	c°	E	H	L	T	S
14.4	365	508	537	559	520	74.00	70.00	14.80	423	302	1052	75.9	93
15.6	395	508	541	562	530	73.50	70.00	11.60	423	302	1052	75.9	93
16.7	425	508	560	579	555	73.00	70.00	8.10	423	302	1063	75.9	93
17.9	455	508	572	585	570	73.00	70.00	5.00	423	302	1069	75.9	93
19.1	485	516	581	589	580	73.00	70.00	2.90	423	302	1074	75.9	103
20.1	510	527	590	595	590	73.00	70.00	1.60	423	302	1080	75.9	115
21.1	535	547	595	599	595	73.00	70.00	1.10	423	302	1085	75.9	136
22.2	565	576	595	598	595	73.00	70.00	1.00	423	302	1086	75.9	165



series

FS-112

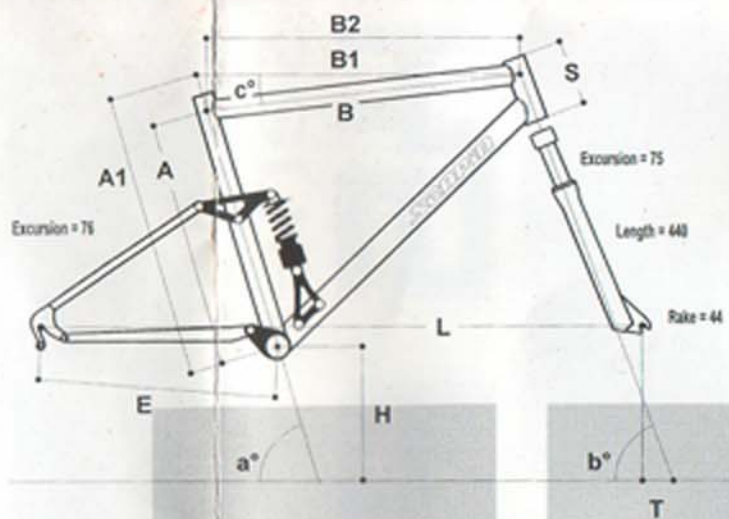

A inch	A mm	A1	B	B1	B2	a°	b°	c°	E	H	L	T	S
15.6	395	495	553	574	545	73.50	70.50	10.20	433	318	1076	70.2	97
16.7	425	508	561	579	555	73.50	70.50	8.31	433	318	1082	70.2	97
17.9	455	508	572	585	570	73.50	70.50	5.12	433	318	1088	70.2	97
19.1	485	513	580	588	580	73.50	70.50	2.66	433	318	1091	70.2	103
20.1	510	524	590	594	590	73.50	70.50	1.33	433	318	1098	70.2	115



HIT TR-X



series HS-X PRO



series HS ELEGANT

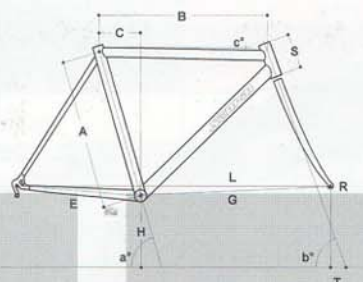

A	B	C	a°	b°	c°	E	H	G	L	R	T	S
470	510	123	75.00	71.00	0.00	398	267	575	861	46	67.0	73
485	520	125	75.00	72.00	0.00	398	267	576	862	46	68.8	80
500	525	133	74.50	71.75	0.00	398	265	576	863	44	64.4	93
510	530	136	74.50	72.50	0.00	398	265	576	863	44	59.8	100
520	535	139	74.50	73.00	0.00	398	264	577	864	44	56.7	107
530	540	146	74.00	72.75	-0.30	400	263	579	868	44	55.2	114
540	545	148	74.00	73.00	-0.30	400	263	582	871	44	56.7	124
550	550	151	74.00	73.25	-0.30	400	263	585	874	44	53.1	132
560	560	159	73.50	73.00	-0.30	402	264	592	883	44	56.7	142
570	565	161	73.50	73.50	-0.50	402	264	593	884	44	53.6	149
580	570	164	73.50	73.50	-0.50	402	264	597	888	44	53.6	159
590	575	173	73.00	73.00	-0.50	404	264	601	894	44	56.7	168
600	575	175	73.00	73.00	-0.70	404	264	601	894	44	56.7	177
615	580	184	72.50	72.50	-1.25	406	266	604	899	44	59.8	189
630	580	189	72.50	72.50	-1.25	406	266	604	899	44	59.8	203



series HS PRO

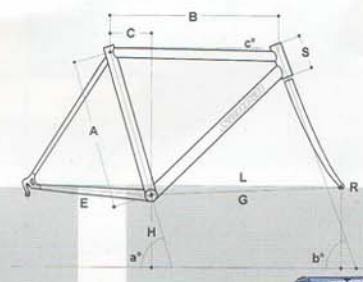

A	B	C	a°	b°	c°	E	H	G	L	R	T	S
500	525	133	74.50	71.75	0.00	398	265	576	863	44	64.4	95
510	530	136	74.50	72.50	0.00	398	265	576	863	44	59.8	102
520	535	139	74.50	73.00	0.00	398	264	577	864	44	56.7	109
530	540	146	74.00	72.75	-0.30	400	263	579	868	44	55.2	116
540	545	148	74.00	73.00	-0.30	400	263	582	871	44	56.7	126
550	550	151	74.00	73.25	-0.30	400	263	585	874	44	53.1	134
560	560	159	73.50	73.00	-0.30	402	264	592	883	44	56.7	144
570	565	161	73.50	73.50	-0.50	402	264	593	884	44	53.6	151
580	570	164	73.50	73.50	-0.50	402	264	597	888	44	53.6	161
590	575	173	73.00	73.00	-0.50	404	264	601	894	44	56.7	170
600	575	175	73.00	73.00	-0.70	404	264	601	894	44	56.7	179
615	580	184	72.50	72.50	-1.25	406	266	604	899	44	59.8	200
630	580	189	72.50	72.50	-1.25	406	266	604	899	44	59.8	205



409**XT-LX**

FORCELLA - FORK
ROCK SHOX JUDY
CAMBIO - REAR DERAILLEUR
XT
COMANDI - SHIFTERS
XT
FRENI - BRAKES
XT a V
GUARNITURA - CRANKSET
LX 42/32/22
MOZZO ANT. - FRONT HUB
LX 32F
MOZZO POST. - REAR HUB
LX 32F
BLOCCAGGI RUOTE - QUICK RELEASE
LX
RUOTA LIBERA - FREEWHEEL
LX 11/28
SERIE STERZO - HEAD SET
DIA COMPE AH 1-1/8
REGGISSELLA - SEAT POST
RITCHEY
SELLA - SADDLE
VETTA TT MANGANESE "BLU SCAPIN"
ATTACCO MANUBRIO - STEM
ITM ECLYPSE "BLU SCAPIN"
PIEGA MANUBRIO - HANDLEBAR
ITM SUPER ALLOY
CERCHI - RIMS
MAVIC SUP 217 "BLU SCAPIN"
RAGGI - SPOKES
ACI INOX RINF.
PNEUMATICI - TIRES
RITCHEY Z-MAX K
PEDALI - PEDALS
RITCHEY LOGIC

509**XT**

FORCELLA - FORK
ROCK SHOX JUDY
CAMBIO - REAR DERAILLEUR
XT
COMANDI - SHIFTERS
XT
FRENI - BRAKES
XT a V
GUARNITURA - CRANKSET
XT 42/32/22
MOZZO ANT. - FRONT HUB
XT32F
MOZZO POST. - REAR HUB
XT32F
BLOCCAGGI RUOTE - QUICK RELEASE
XT
RUOTA LIBERA - FREEWHEEL
XT 11/28
SERIE STERZO - HEAD SET
DIA COMPE AH 1-1/8
REGGISSELLA - SEAT POST
ZOOM MICROSET
SELLA - SADDLE
VETTA TT MANGANESE "BLU SCAPIN"
ATTACCO MANUBRIO - STEM
3TTT FORGE AHEAD "BLU SCAPIN"
PIEGA MANUBRIO - HANDLEBAR
3TTT
CERCHI - RIMS
MAVIC SUP 217 "BLU SCAPIN"
RAGGI - SPOKES
ACI INOX RINF.
PNEUMATICI - TIRES
RITCHEY Z-MAX K
PEDALI - PEDALS
RITCHEY LOGIC

609**XT MIX**

FORCELLA - FORK
ROCK SHOX JUDY
CAMBIO - REAR DERAILLEUR
XT
COMANDI - SHIFTERS
XT
FRENI - BRAKES
XT a V
GUARNITURA - CRANKSET
COOK 42 /32/22
MOZZO ANT. - FRONT HUB
STM 32 F
MOZZO POST. - REAR HUB
STM 32F
BLOCCAGGI RUOTE - QUICK RELEASE
SALSA
RUOTA LIBERA - FREEWHEEL
XT 11/28
SERIE STERZO - HEAD SET
DIA COMPE AH 1-1/8
REGGISSELLA - SEAT POST
ZOOM MICROSET
SELLA - SADDLE
VETTA TT MANGANESE "BLU SCAPIN"
ATTACCO MANUBRIO - STEM
3TTT FORGE AHEAD "BLU SCAPIN"
PIEGA MANUBRIO - HANDLEBAR
3TTT
CERCHI - RIMS
MAVIC SUP 217 "BLU SCAPIN"
RAGGI - SPOKES
ACI INOX RINF.
PNEUMATICI - TIRES
RITCHEY Z-MAX K WCS
PEDALI - PEDALS
RITCHEY PRO WCS TITANIO

FS-X2

TELAIO - FRAME
FS - X2 TUBI COLUMBUS NEMO PROGETTO SCAPIN
QUADRUPLO SPESSORE
FORCELLA - FORK
ROCK SHOX JUDY
ATTACCO MANUBRIO - STEM
3 TTT FORGE AHEAD "BLU SCAPIN"
REGGISSELLA - SEAT POST
ZOOM MICROSET
SERIE STERZO - HEAD SET
DIA COMPE AH 1-1/8

TR-X

TELAIO - FRAME
TR-X TUBI DEDACCIAI PROGETTO SCAPIN
18 MCDV6HT TRIPLO SPESSORE
FORCELLA - FORK
ROCK SHOX JUDY
ATTACCO MANUBRIO - STEM
3 TTT FORGE AHEAD "BLU SCAPIN"
REGGISSELLA - SEAT POST
ZOOM MICROSET
SERIE STERZO - HEAD SET
DIA COMPE AH 1-1/8

VR-X

TELAIO - FRAME
VR-X TUBI DEDACCIAI PROGETTO SCAPIN
18 MCDV6 DOPPIO SPESSORE
FORCELLA - FORK
ROCK SHOX JUDY
ATTACCO MANUBRIO - STEM
ITM ECLYPSE "BLU SCAPIN"
REGGISSELLA - SEAT POST
RITCHEY
SERIE STERZO - HEAD SET
DIA COMPE AH 1-1/8

RECORD

GRUPPO - COMPONENT GROUP
CAMPAGNOLO RECORD

ATTACCO MANUBRIO - STEM
ITM ECLYPSE "BLU SCAPIN"

PIEGA MANUBRIO - HANDLEBAR
ITM PRO

SELLA - SADDLE
VETTA TT MANGANESE "BLU SCAPIN"

CERCHI - RIMS
MAVIC SUP CXP 30

RAGGI - SPOKES
ACI INOX

PNEUMATICI - TIRES
VITTORIA OPEN

CHORUS

GRUPPO - COMPONENT GROUP
CAMPAGNOLO CHORUS

ATTACCO MANUBRIO - STEM
ITM ECLYPSE "BLU SCAPIN"

PIEGA MANUBRIO - HANDLEBAR
ITM PRO

SELLA - SADDLE
VETTA TT MANGANESE "BLU SCAPIN"

CERCHI - RIMS
MAVIC SUP CXP 30

RAGGI - SPOKES
ACI INOX

PNEUMATICI - TIRES
VITTORIA TECNO

MIRAGE

GRUPPO - COMPONENT GROUP
CAMPAGNOLO MIRAGE

ATTACCO MANUBRIO - STEM
ITM ECLYPSE "BLU SCAPIN"

PIEGA MANUBRIO - HANDLEBAR
ITM S/EUROPA

SELLA - SADDLE
VETTA TT MANGANESE "BLU SCAPIN"

CERCHI - RIMS
MAVIC SUP CXP 30

RAGGI - SPOKES
ACI INOX

PNEUMATICI - TIRES
VITTORIA TECNO

METAL**ROAD**