



H.O. BRAKE HIGH OUTPUT

INSTRUCTIONS

PART NUMBERS

front #BBR-0501

rear #BBR-0502

WARRANTY IS VOID UNLESS THIS PRODUCT IS INSTALLED BY A PROFESSIONAL BICYCLE SHOP

step 1

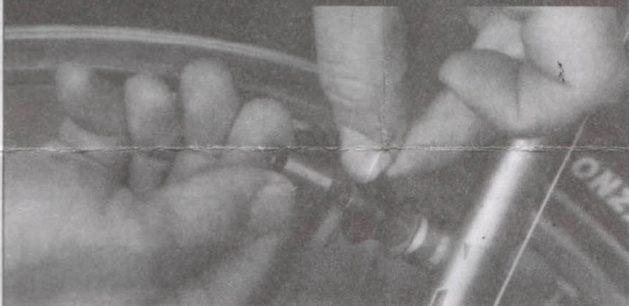

Clean all grease from brake post and install spring tension adjuster and steel sleeve. Lubricate outer surface with a light coat of grease.

steps 2

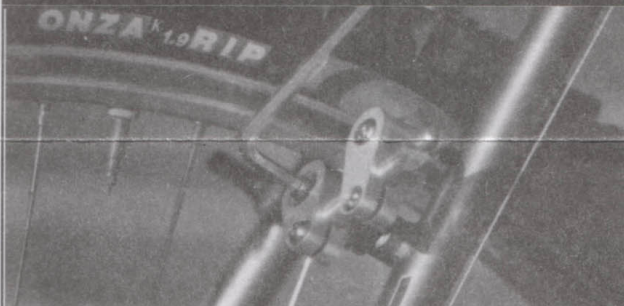

2. Looking at brake posts [from front of bike for front brakes, from rear of bike for rear brakes] place gold spring on the right post and the silver spring on the left post.

- Install brake arm assemblies.
- Using a 5mm hex wrench, snug mounting bolts into brake posts.

step 3

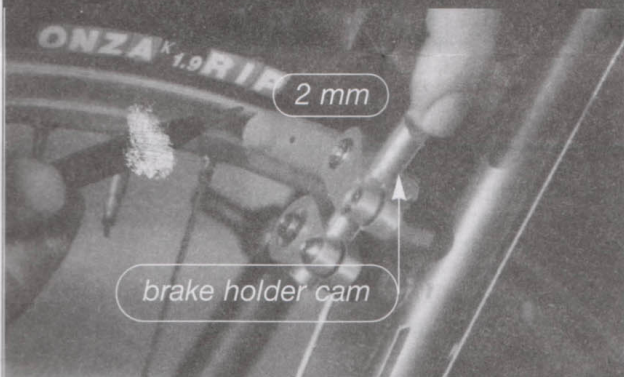

- Raise or lower brake holder cam so that brake pad will squarely contact the rim. Brake Pad should be at least 2mm from tire.

step 4

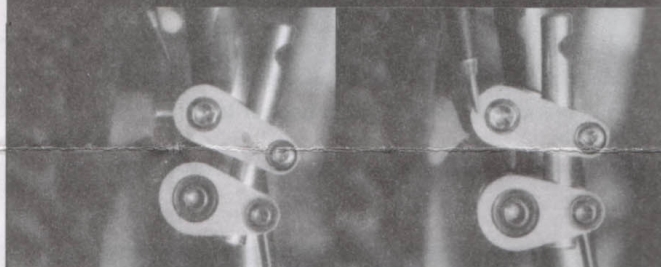

Hold brake pad squarely against the rim and tighten the pad adjuster bolt. Both pads must be adjusted exactly the same. Torque bolts to 6.8 N-m {5 ft-lb}

Adjusting pad closer to brake holder cam results in a more progressive feel. Moving pad away from cam will increase braking power and decrease progressiveness.

step 5

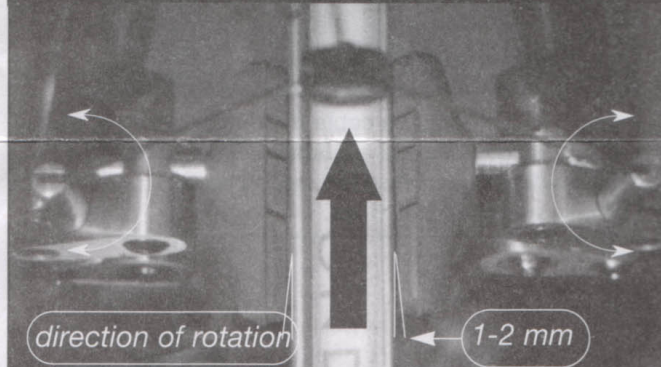

direction of rotation

1-2 mm

Rotate the brake holder cam. There should be a 1mm to 2mm gap at the rear of the brake pad when the front is touching the rim. Torque each pad to 6.8 N-m {5 ft-lb}

step 6



To adjust spring tension, loosen brake arm mounting bolts. Using a 15mm spanner, rotate spring tension adjuster until desired tension is achieved. Holding adjuster in place, tighten the brake mounting bolts to 6.8 N-m {5 ft-lb} CAUTION: DO NOT OVER TIGHTEN BRAKE ARM MOUNTING BOLTS, DOING SO WILL DAMAGE THE BRAKE POSTS.

step 7

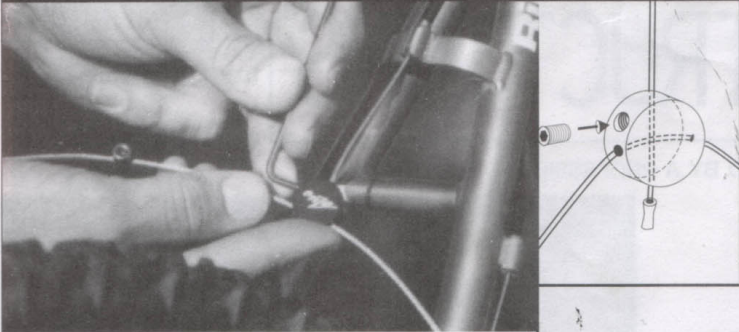

Secure **chill pill**™ cable hanger to brake cable.

step 9

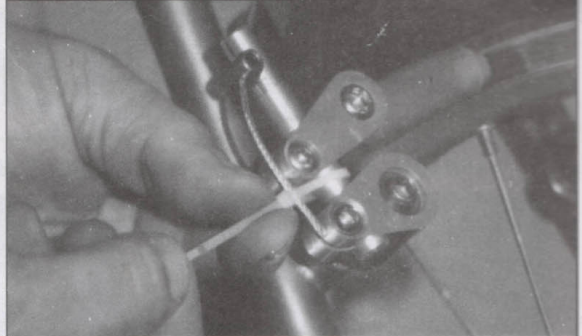

Trim extra straddle cable approx 50mm. Secure excess to brake arm with enclosed zip tie.

step 8

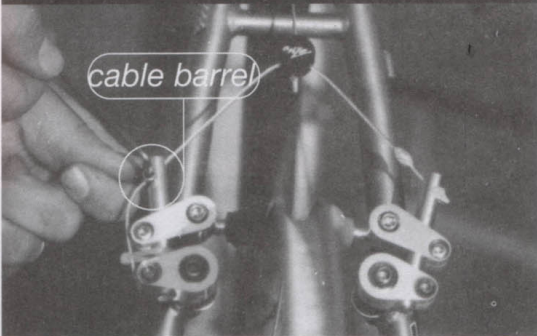

Insert end of straddle cable through hole in cable hanger. Secure adjustable cable barrel to straddle cable. Position cables as per photo and secure all bolts.

extra notes

- Periodically check tightness of bolts on Holder Cam and Lower Cam.
- Periodically check bolt tightness in Chill Pill cable hanger.

brake arm assembly

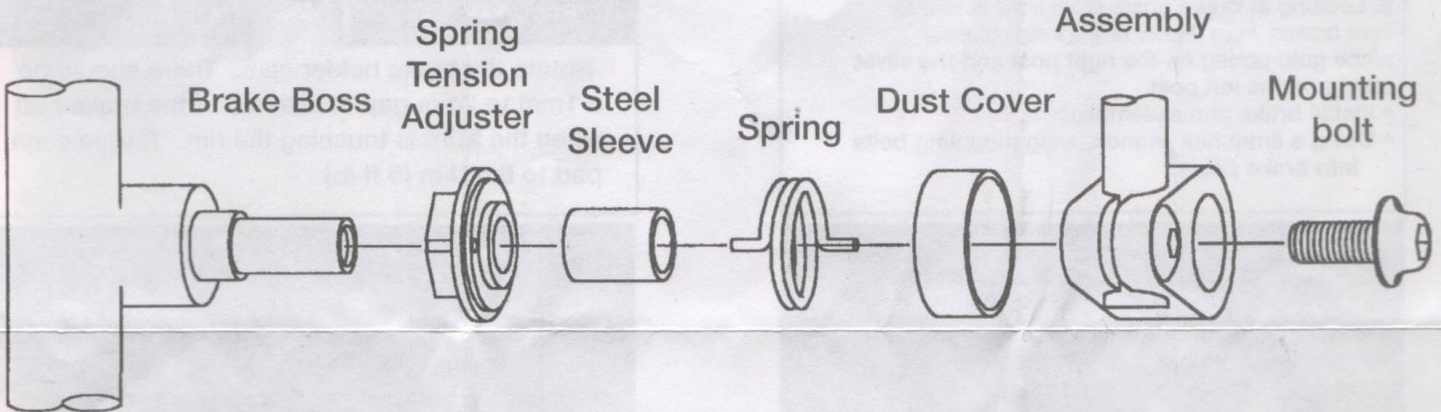
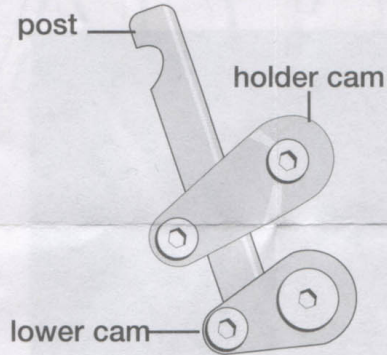

LIMITED WARRANTY

ONZA WARRANTS THIS PRODUCT TO BE FREE FROM DEFECTS IN MATERIAL AND WORKMANSHIP FOR A PERIOD OF ONE YEAR. ONZA WILL AT IT'S SOLE DETERMINATION, REPAIR, OR REPLACE ANY PART OF THIS PRODUCT FOUND TO BE DEFECTIVE, NORMAL WEAR AND TEAR EXCLUDED. SHIPPING AND / OR DEALER LABOR CHARGES ARE NOT COVERED BY THIS WARRANTY. THIS LIMITED WARRANTY DISCLAIMS ALL IMPLIED WARRANTIES AFTER EXPIRATION OF THIS EXPRESS LIMITED WARRANTY. INCIDENTAL OR CONSEQUENTIAL DAMAGES THAT MAY RESULT FROM THE FAILURE OR MALFUNCTION OF THIS PRODUCT ARE NOT COVERED BY THIS WARRANTY.

